

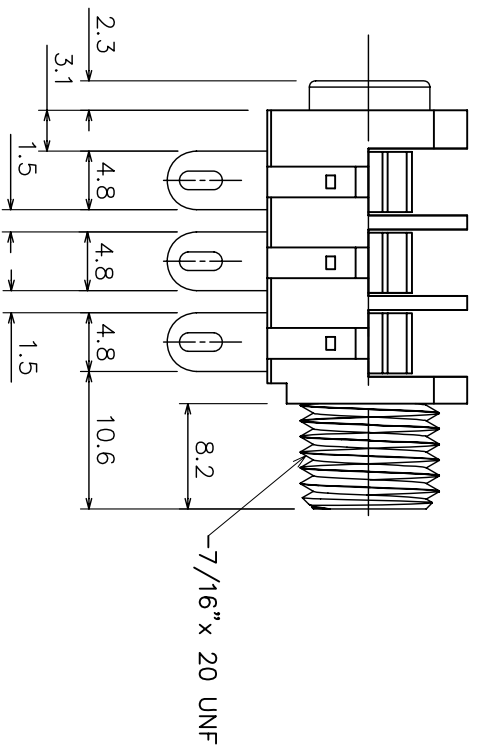

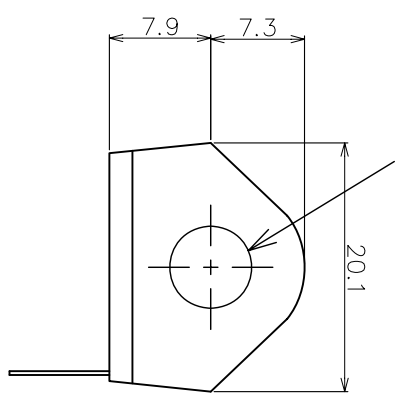

INTERNAL HOLE DIA. Ø6.4

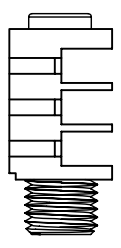

MATERIAL PROPERTIES

Parts	Description	Material	Remark
	Jack Body	Polyamide	Black
	FIBRE WASHER (1.6mm Th.)	Vulcanized Fibre	Black
	Plastic Nut	Polyamide	Black
	Metal Contact	Nickel Silver	Tin Plated

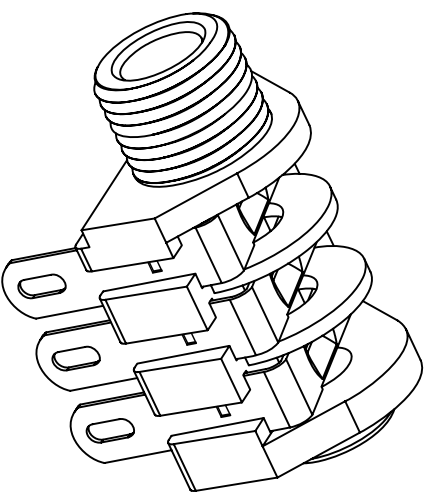

ISOMETRIC VIEW

DIMENSIONS IN MILLIMETERS
3rd ANGLE PROJECTION
SCALE: N.T.S.

SUPPLY NUTS AND WASHERS AS LOOSE PARTS.

DRAWN PYQ	MATERIAL: AS TABLE	CHECKED PCS	FINISH: AS MOULDED
ISSUE 1	AMEND		

TOLERANCES
NO DECIMAL PLACE ± 1.0
1 DECIMAL PLACE ± 0.5
2 DECIMAL PLACES ± 0.1
DIAMETER HOLES ± 0.1
ANGLES ± 1/2 DEGREE
(UNLESS OTHERWISE STATED)



TITLE: 6.35 PHONE JACK, SOLDER TAG/SSS

DRWG NO: JT-2220