

ISOMETRIC VIEWS

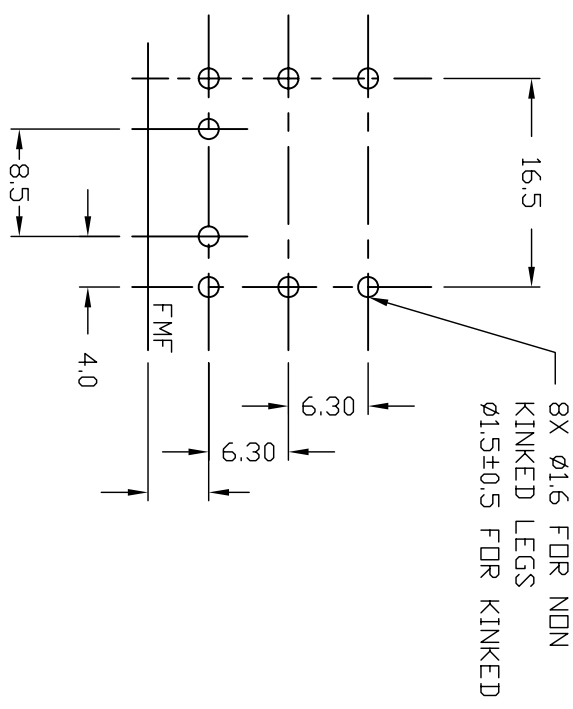
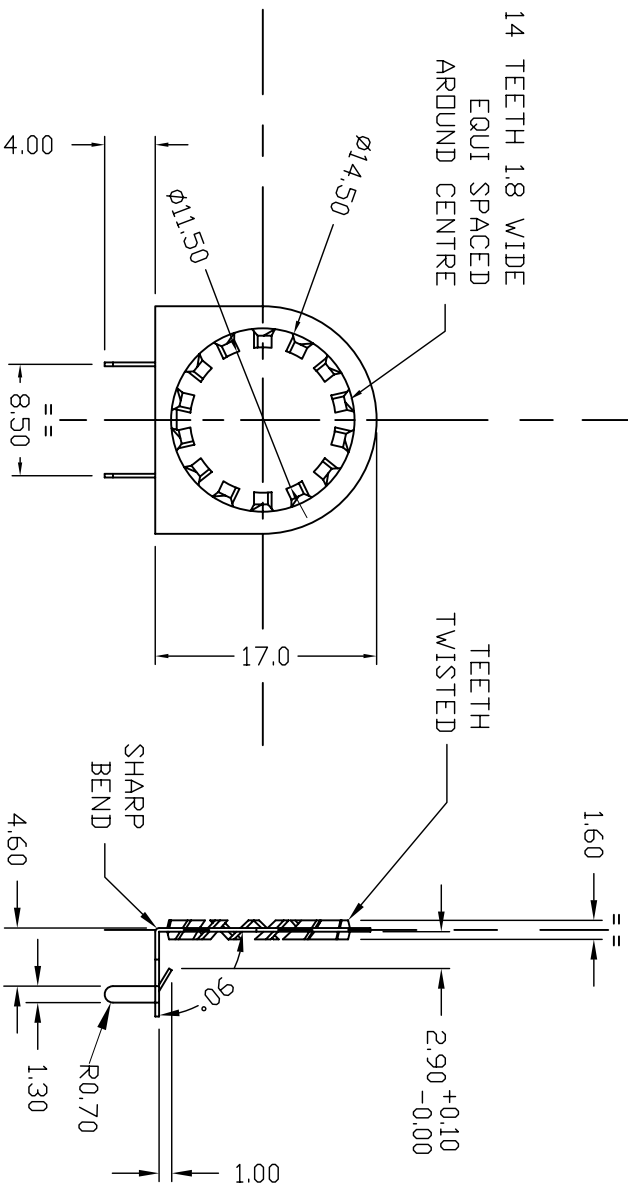
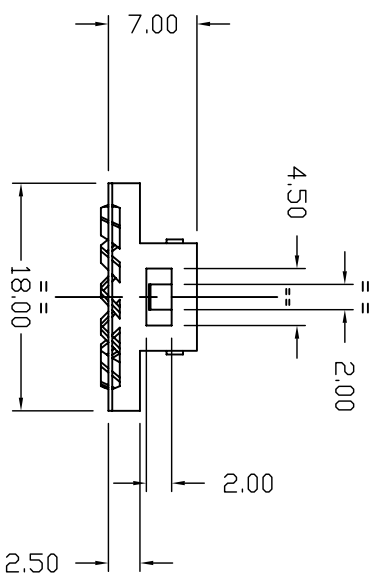
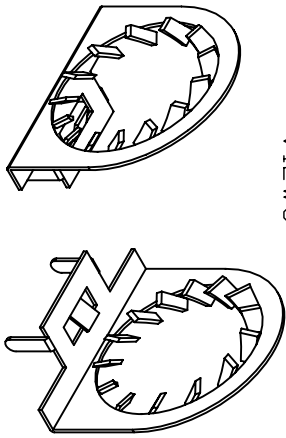

Note:
 1. Spring Steel Thickness 0.32mm ± 0.05mm
 2. Spring Steel must be Cleaned, De-Embrittled & Heat-Treated

DIMENSIONS IN MILLIMETERS	
3rd ANGLE PROJECTION	
SCALE: N.T.S	
DO NOT SCALE	

ISSUE	AMEND	DATE
1	1st DRAWN	07/05/08
2	WAS CL14427HK	24/07/09

DRAWN	XHZ	MATERIAL:	SPRING STEEL
CHECKED	PCS	FINISH:	TIN PLATED (MUST BE SOLDERABLE)

TOLERANCES	
NO DECIMAL PLACE	± 0.5
1 DECIMAL PLACE	± 0.2
2 DECIMAL PLACES	± 0.1
DIAMETER HOLES	± 0.1
ANGLES	± 1/2 DEGREE
(UNLESS OTHERWISE STATED)	



TITLE: 14 TEETH EARTHING WASHER FOR
 TYPE 4 JSKT

DRWG NO.: MM-4060

