

**INTERNAL HOLE DIA. Ø6.4**

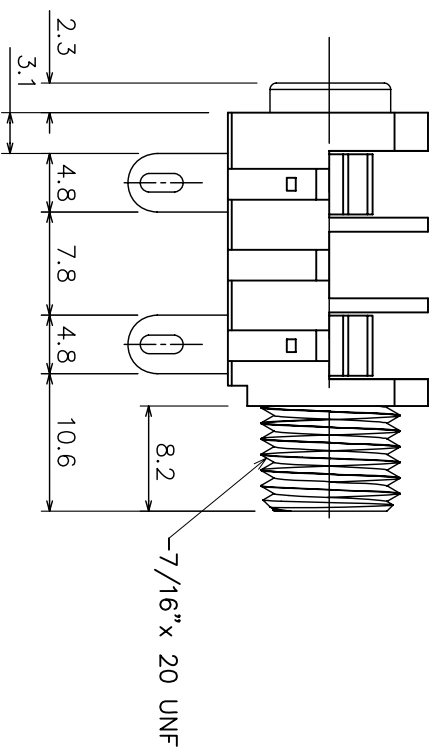

**MATERIAL PROPERTIES**

Parts	Description	Material	Remark
	Jack Body	Polyamide	White
	FIBRE WASHER (1.6mm Th.)	Vulcanized Fibre	Black
	Plastic Nut	Polyamide	White
	Metal Contact	Nickel Silver	Tin Plated

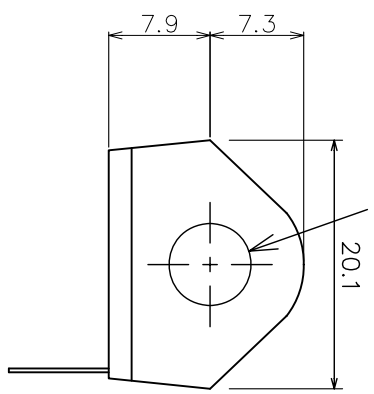
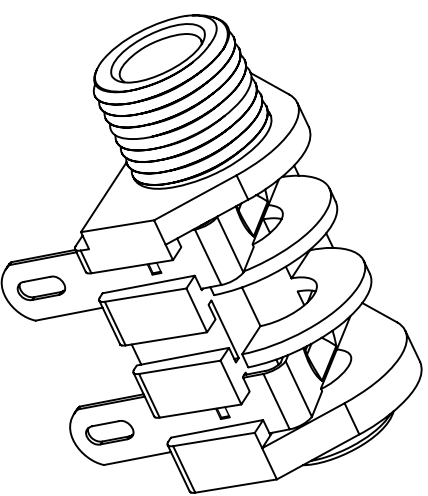

ISOMETRIC VIEW

**H DIMENSIONS IN MILLIMETERS**  
3rd ANGLE PROJECTION  
SCALE: N.T.S.

SUPPLY NUTS AND WASHERS AS LOOSE PARTS.

DRAWN PYQ MATERIAL: AS TABLE

ISSUE	AMEND	DATE	CHECKED PCS	FINISH: AS MOULDED	TOLERANCES
1	1st DRAWN	05/07/14			NO DECIMAL PLACE ± 1.0 1 DECIMAL PLACE ± 0.5 2 DECIMAL PLACES ± 0.1 DIAMETER HOLES ± 0.1 ANGLES ± 1/2 DEGREE (UNLESS OTHERWISE STATED)

TITLE: 6.35 PHONE JACK, SOLDER TAGS/NS

DRWG NO.: JT-202W

