

M9 NUT  
2.0mm THK

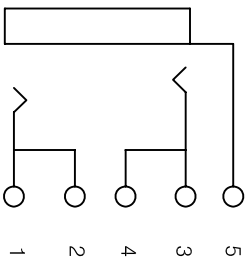

WASHER  
0.5mm THK

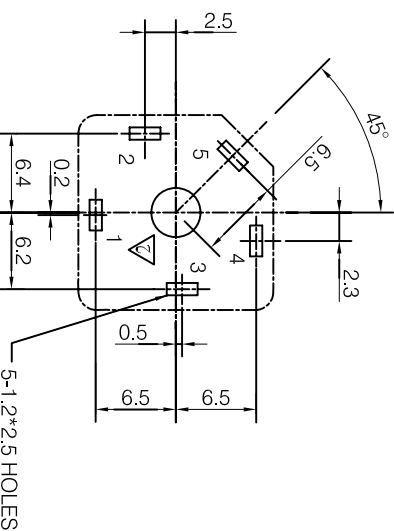
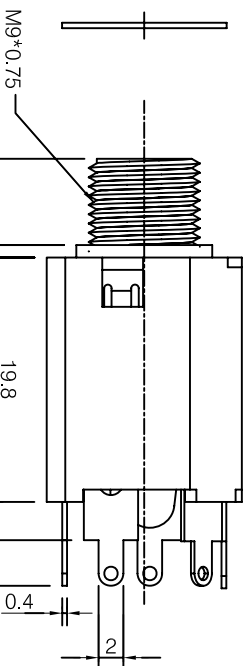

SCHEMATIC

PCB LAYOUT  
(BOTTOM VIEW)

TOL : ±0.1

DIMENSIONS IN MILLIMETERS  
3rd ANGLE PROJECTION  
SCALE: N.T.S  
DO NOT SCALE

DRAWN: PYQ  
MATERIAL: PBT / BRONZE / SILVER PLATED

TOLERANCES

- NO DECIMAL PLACE ± 0.5
- 1 DECIMAL PLACE ± 0.2
- 2 DECIMAL PLACES ± 0.1
- DIAMETER HOLES ± 0.1
- ANGLES ± 1/2 DEGREE
- (UNLESS OTHERWISE STATED)

CHECKED: PCS  
FINISH: CLEAN

ISSUE	AMEND	DATE
1	1st DRAWN	23/02/16



TITLE: VERTICAL JACK SIV/SBB, METAL  
NOSE W NUT & WASHER, SOLDER TAG  
DRWG NO: JM-1210

